

Chapter 6

The Link Layer and LANs

A note on the use of these Powerpoint slides:

We're making these slides freely available to all (faculty, students, readers). They're in PowerPoint form so you see the animations; and can add, modify, and delete slides (including this one) and slide content to suit your needs. They obviously represent a *lot* of work on our part. In return for use, we only ask the following:

- If you use these slides (e.g., in a class) that you mention their source (after all, we'd like people to use our book!)
- If you post any slides on a www site, that you note that they are adapted from (or perhaps identical to) our slides, and note our copyright of this material.

Thanks and enjoy! JFK/KWR

© All material copyright 1996-2016
J.F Kurose and K.W. Ross, All Rights Reserved

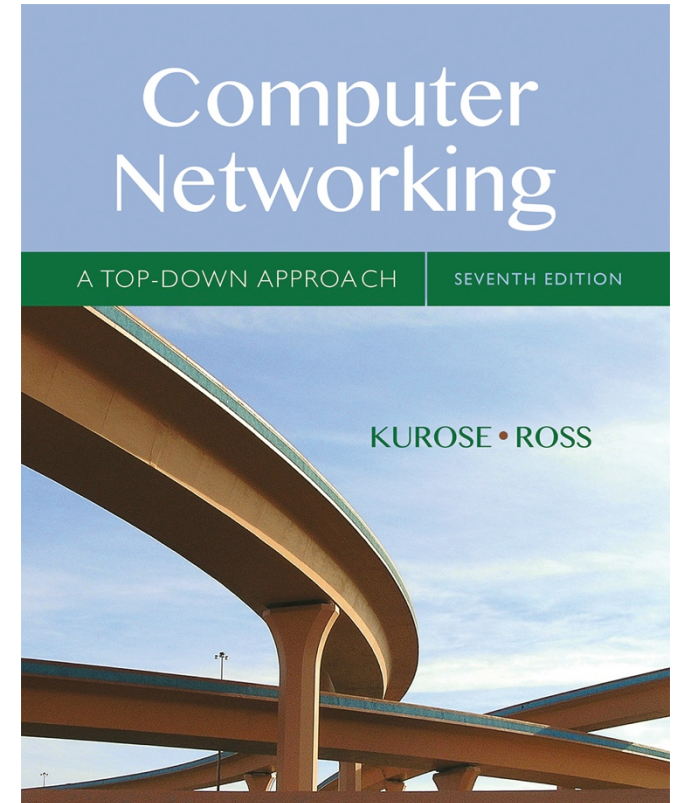

Computer Networking: A Top Down Approach

7th edition

Jim Kurose, Keith Ross

Pearson/Addison Wesley

April 2016

Chapter 6: Link layer and LANs

our goals:

- understand principles behind link layer services:
 - error detection, correction
 - sharing a broadcast channel: multiple access
 - link layer addressing
 - local area networks: Ethernet, VLANs
- instantiation, implementation of various link layer technologies

Link layer, LANs: outline

6.1 introduction, services

6.2 error detection,
correction

6.3 multiple access
protocols

6.4 LANs

- addressing, ARP
- Ethernet
- switches
- VLANs

6.5 link virtualization:
MPLS

6.6 data center
networking

6.7 a day in the life of a
web request

Link layer: introduction

terminology:

- hosts and routers: **nodes**
- communication channels that connect adjacent nodes along communication path: **links**
 - wired links
 - wireless links
 - LANs
- layer-2 packet: **frame**, encapsulates datagram

data-link layer has responsibility of transferring datagram from one node to *physically adjacent* node over a link

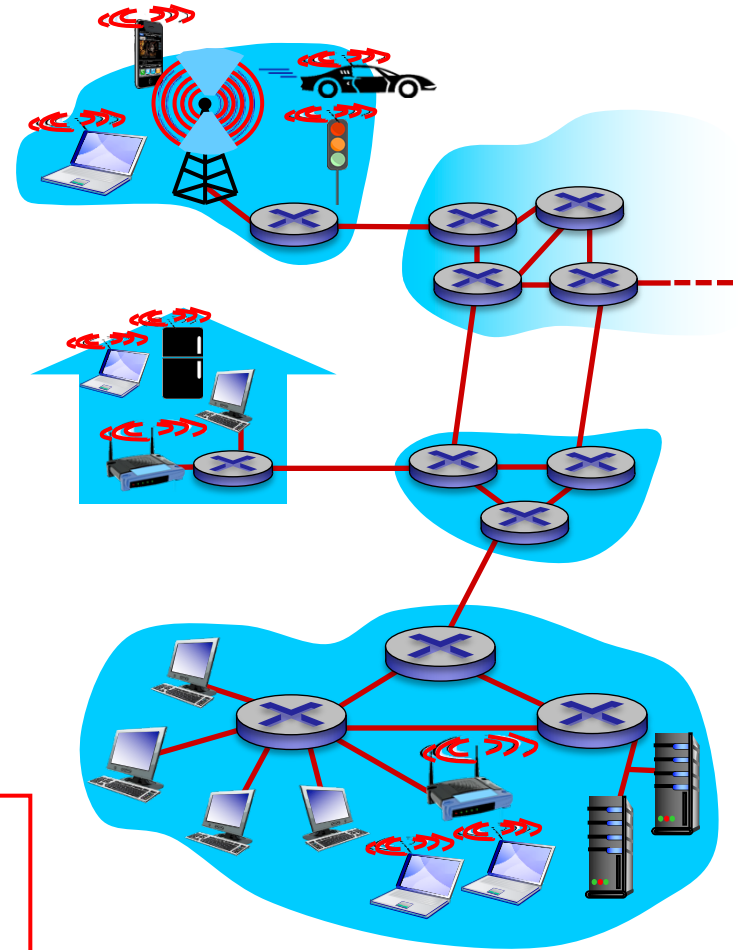

Link layer: context

- datagram transferred by different link protocols over different links:
 - e.g., Ethernet on first link, frame relay on intermediate links, 802.11 on last link
- each link protocol provides different services
 - e.g., may or may not provide rdt over link

transportation analogy:

- trip from Princeton to Lausanne
 - limo: Princeton to JFK
 - plane: JFK to Geneva
 - train: Geneva to Lausanne
- tourist = **datagram**
- transport segment = **communication link**
- transportation mode = **link layer protocol**
- travel agent = **routing algorithm**

Link layer services

- *framing, link access:*
 - encapsulate datagram into frame, adding header, trailer
 - channel access if shared medium
 - “MAC” addresses used in frame headers to identify source, destination
 - different from IP address!
- *reliable delivery between adjacent nodes*
 - we learned how to do this already (chapter 3)!
 - seldom used on low bit-error link (fiber, some twisted pair)
 - wireless links: high error rates
 - **Q:** why both link-level and end-end reliability?

Link layer services (more)

- *flow control*:
 - pacing between adjacent sending and receiving nodes
- *error detection*:
 - errors caused by signal attenuation, noise.
 - receiver detects presence of errors:
 - signals sender for retransmission or drops frame
- *error correction*:
 - receiver identifies *and corrects* bit error(s) without resorting to retransmission
- *half-duplex and full-duplex*
 - with half duplex, nodes at both ends of link can transmit, but not at same time

Where is the link layer implemented?

- in each and every host
- link layer implemented in “adaptor” (aka *network interface card* NIC) or on a chip
 - Ethernet card, 802.11 card; Ethernet chipset
 - implements link, physical layer
- attaches into host’s system buses
- combination of hardware, software, firmware

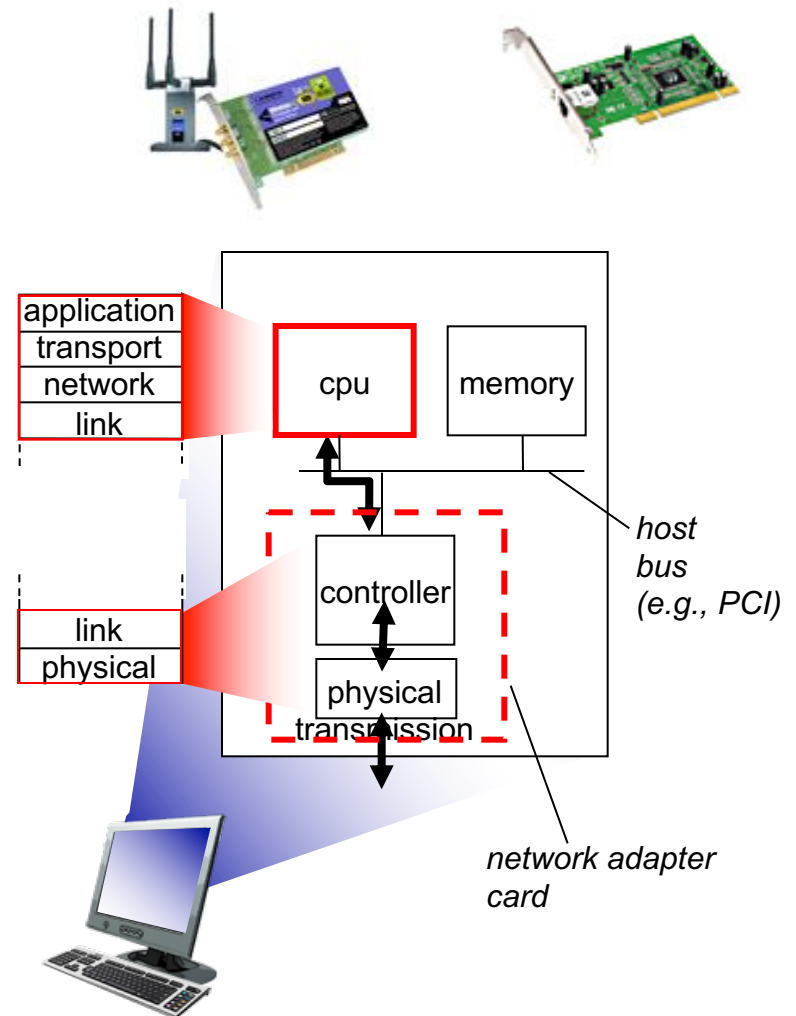

Adaptors communicating

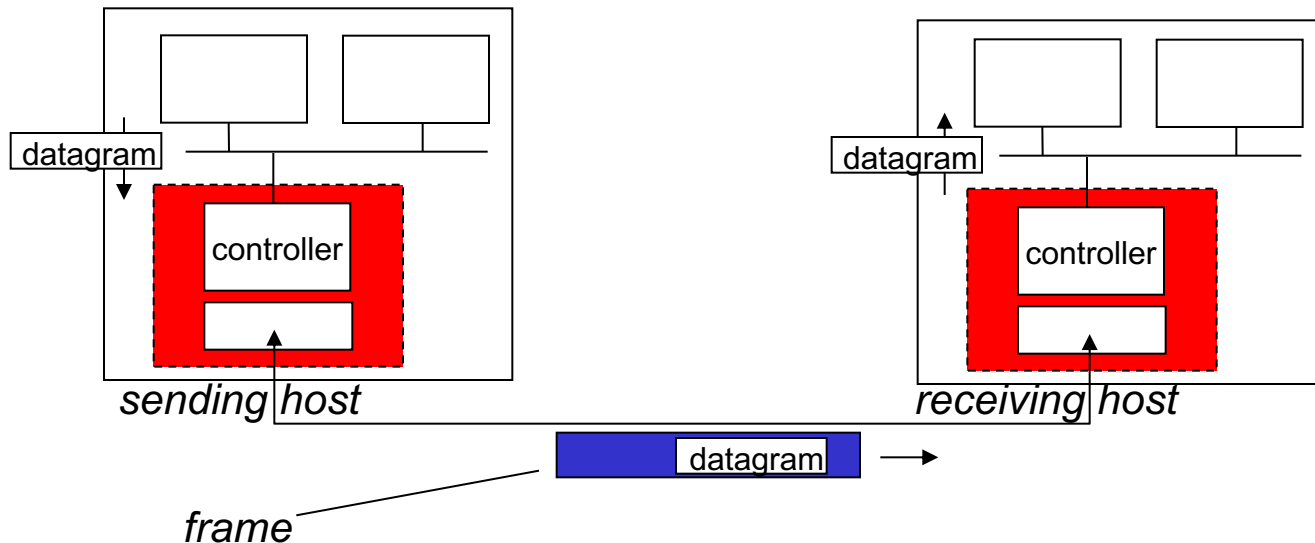

- sending side:
 - encapsulates datagram in frame
 - adds error checking bits, rdt, flow control, etc.
- receiving side
 - looks for errors, rdt, flow control, etc.
 - extracts datagram, passes to upper layer at receiving side

Link layer, LANs: outline

6.1 introduction, services

6.2 error detection,
correction

6.3 multiple access
protocols

6.4 LANs

- addressing, ARP
- Ethernet
- switches
- VLANs

6.5 link virtualization:
MPLS

6.6 data center
networking

6.7 a day in the life of a
web request

Error detection

EDC= Error Detection and Correction bits (redundancy)

D = Data protected by error checking, may include header fields

- Error detection not 100% reliable!
 - protocol may miss some errors, but rarely
 - larger EDC field yields better detection and correction

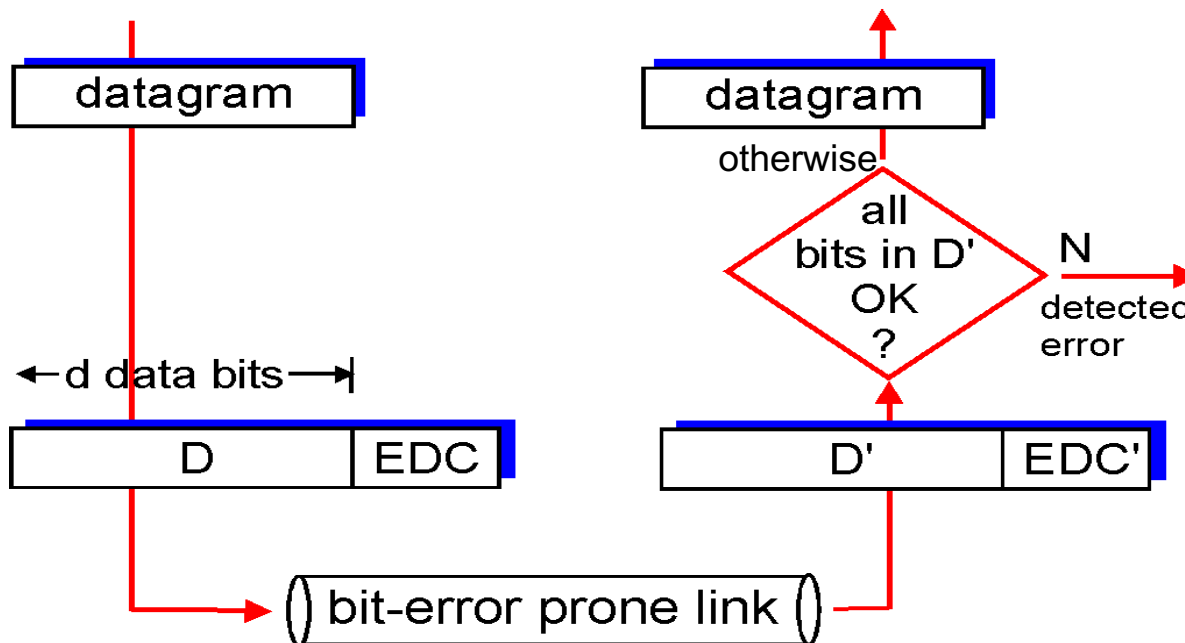

Parity checking

single bit parity:

- detect single bit errors

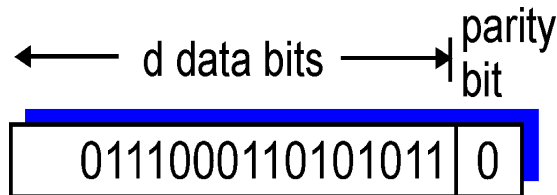

two-dimensional bit parity:

- detect and correct single bit errors

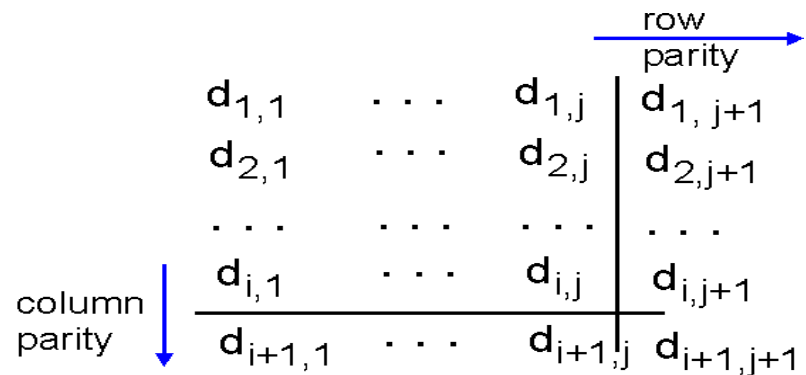

1	0	1	0	1	1
1	1	1	1	0	0
0	1	1	1	0	1
0	0	1	0	1	0

no errors

1	0	1	0	1	1
1	0	1	1	0	0
0	1	1	1	0	1
0	0	1	0	1	0

parity error

*correctable
single bit error*

* Check out the online interactive exercises for more examples: http://gaia.cs.umass.edu/kurose_ross/interactive/

Internet checksum (review)

goal: detect “errors” (e.g., flipped bits) in transmitted packet
(note: used at transport layer only)

sender:

- treat segment contents as sequence of 16-bit integers
- checksum: addition (1’s complement sum) of segment contents
- sender puts checksum value into UDP checksum field

receiver:

- compute checksum of received segment
- check if computed checksum equals checksum field value:
 - NO - error detected
 - YES - no error detected.
But maybe errors nonetheless?

Cyclic redundancy check

- more powerful error-detection coding
- view data bits, **D**, as a binary number
- choose $r+1$ bit pattern (generator), **G**
- goal: choose r CRC bits, **R**, such that
 - $\langle D, R \rangle$ exactly divisible by G (modulo 2)
 - receiver knows G , divides $\langle D, R \rangle$ by G . If non-zero remainder: error detected!
 - can detect all burst errors less than $r+1$ bits
- widely used in practice (Ethernet, 802.11 WiFi, ATM)

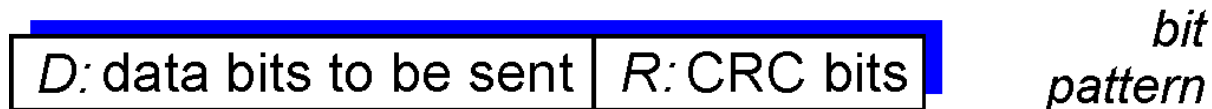
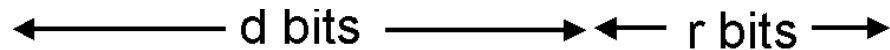

$$D * 2^r \text{ XOR } R$$

mathematical formula

Link layer, LANs: outline

6.1 introduction, services

6.2 error detection,
correction

6.3 multiple access
protocols

6.4 LANs

- addressing, ARP
- Ethernet
- switches
- VLANs

6.5 link virtualization:
MPLS

6.6 data center
networking

6.7 a day in the life of a
web request

Multiple access links, protocols

two types of “links”:

- point-to-point
 - PPP for dial-up access
 - point-to-point link between Ethernet switch, host
- *broadcast (shared wire or medium)*
 - old-fashioned Ethernet
 - upstream HFC
 - 802.11 wireless LAN



shared wire (e.g.,
cabled Ethernet)



shared RF
(e.g., 802.11 WiFi)

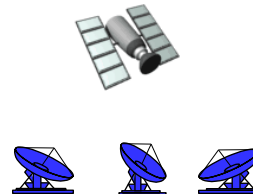

shared RF
(satellite)



humans at a
cocktail party
(shared air, acoustical)

Multiple access protocols

- single shared broadcast channel
- two or more simultaneous transmissions by nodes: interference
 - *collision* if node receives two or more signals at the same time

multiple access protocol

- distributed algorithm that determines how nodes share channel, i.e., determine when node can transmit
- communication about channel sharing must use channel itself!
 - no out-of-band channel for coordination

An ideal multiple access protocol

given: broadcast channel of rate R bps

desiderata:

1. when one node wants to transmit, it can send at rate R .
2. when M nodes want to transmit, each can send at average rate R/M
3. fully decentralized:
 - no special node to coordinate transmissions
 - no synchronization of clocks, slots
4. simple

MAC protocols: taxonomy

three broad classes:

- *channel partitioning*
 - divide channel into smaller “pieces” (time slots, frequency, code)
 - allocate piece to node for exclusive use
- *random access*
 - channel not divided, allow collisions
 - “recover” from collisions
- *“taking turns”*
 - nodes take turns, but nodes with more to send can take longer turns

Channel partitioning MAC protocols: TDMA

TDMA: time division multiple access

- access to channel in "rounds"
- each station gets fixed length slot (length = packet transmission time) in each round
- unused slots go idle
- example: 6-station LAN, 1,3,4 have packets to send, slots 2,5,6 idle

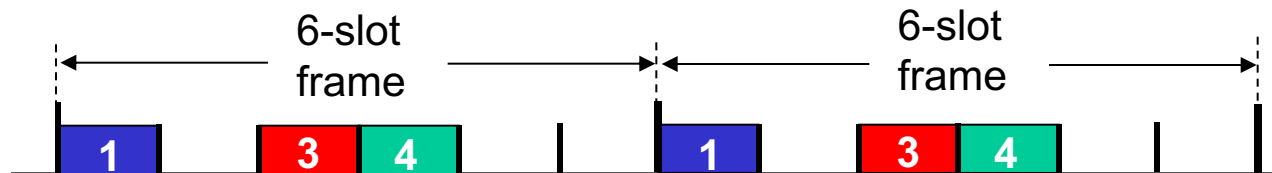

Channel partitioning MAC protocols: FDMA

FDMA: frequency division multiple access

- channel spectrum divided into frequency bands
- each station assigned fixed frequency band
- unused transmission time in frequency bands go idle
- example: 6-station LAN, 1,3,4 have packet to send, frequency bands 2,5,6 idle

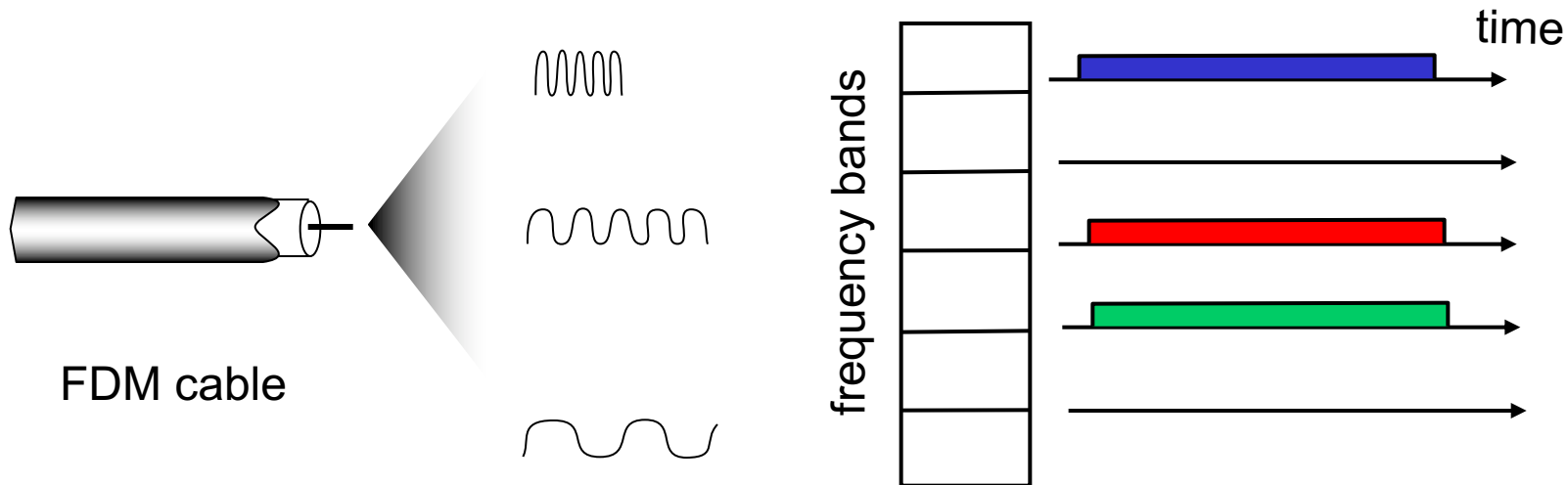

Random access protocols

- when node has packet to send
 - transmit at full channel data rate R .
 - no *a priori* coordination among nodes
- two or more transmitting nodes → “collision”,
- **random access MAC protocol** specifies:
 - how to detect collisions
 - how to recover from collisions (e.g., via delayed retransmissions)
- examples of random access MAC protocols:
 - slotted ALOHA
 - ALOHA
 - CSMA, CSMA/CD, CSMA/CA